



High Technology in Refrigeration Devices

PRODUCT DOCUMENTATION

NRG
Air Conditioning units for Close Control Application
with inverter driven compressors

"R" Advanced Direct Driven Plug fans

- NA..R → Direct Expansion Up/Down Flow
- NW..R → Direct Expansion Water cooled Up/Down Flow
- N..XR → Direct Expansion Displacement Version

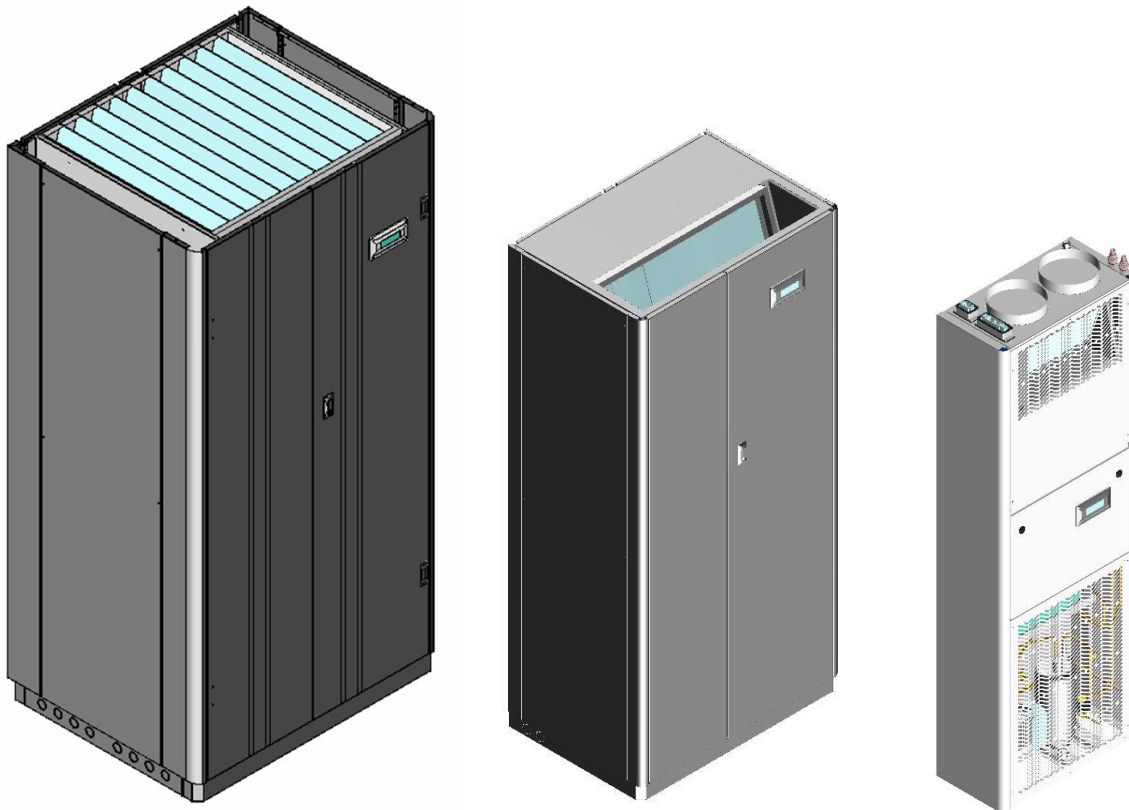



Index

General Description	<input type="checkbox"/>
Configuration Digit	<input type="checkbox"/>
Main characteristics & features	<input type="checkbox"/>
Application field	<input type="checkbox"/>
Technical section	<input type="checkbox"/>
Overview of the range	<input type="checkbox"/>
DX Air Cooled Units Technical Data	<input type="checkbox"/>
DX Water Cooled Units Technical Data	<input type="checkbox"/>
Remote Condensers	<input type="checkbox"/>
Remote Dry Coolers	<input type="checkbox"/>
Correction factors	<input type="checkbox"/>
Drawings	<input type="checkbox"/>
Legend	<input type="checkbox"/>

General Description of NRG NADR 261

Example of a DX Air Cooled Unit Type NADR:

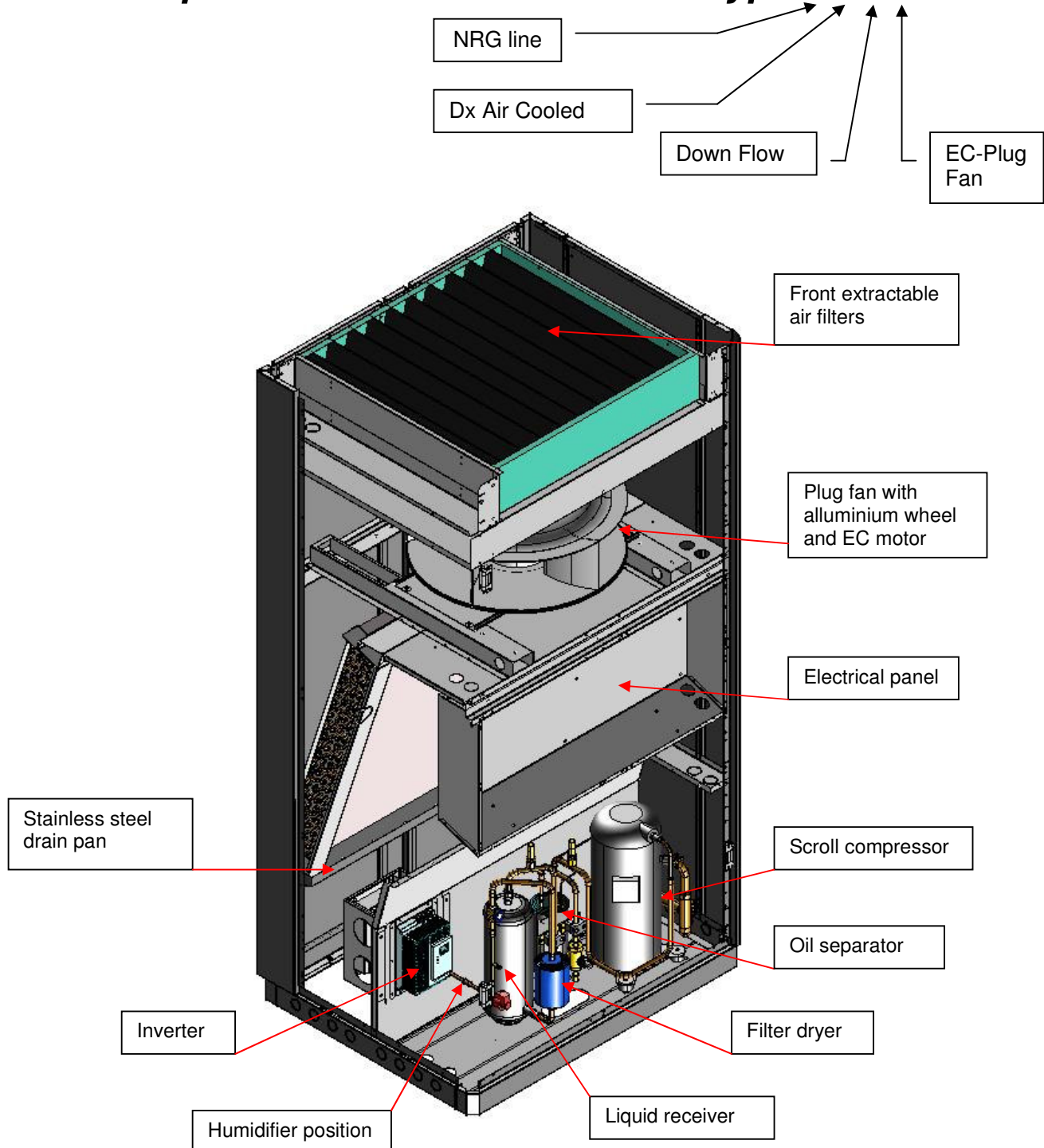

General Description of NRG NADR 130

Example of a DX Air Cooled Unit Type NADR:

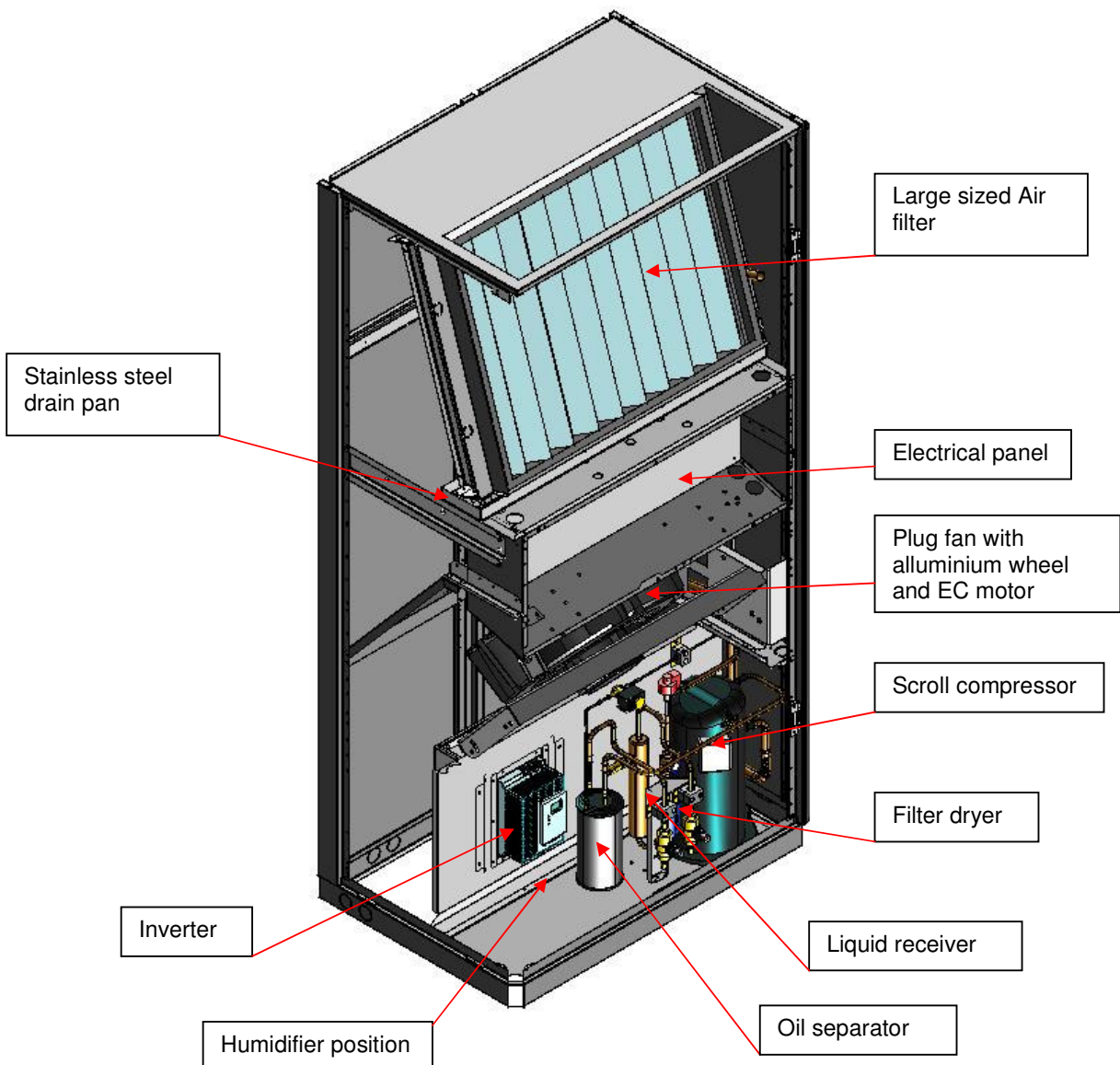
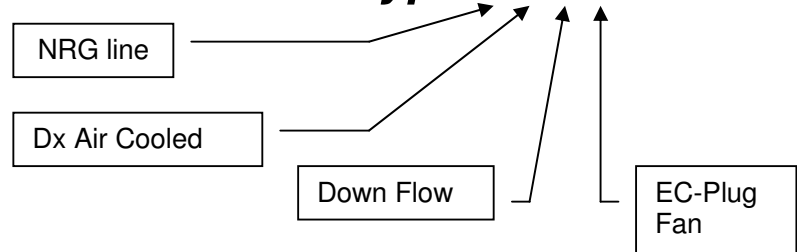

General Description of NRG NADR 060

Example of a DX Air Cooled Unit Type NADR:

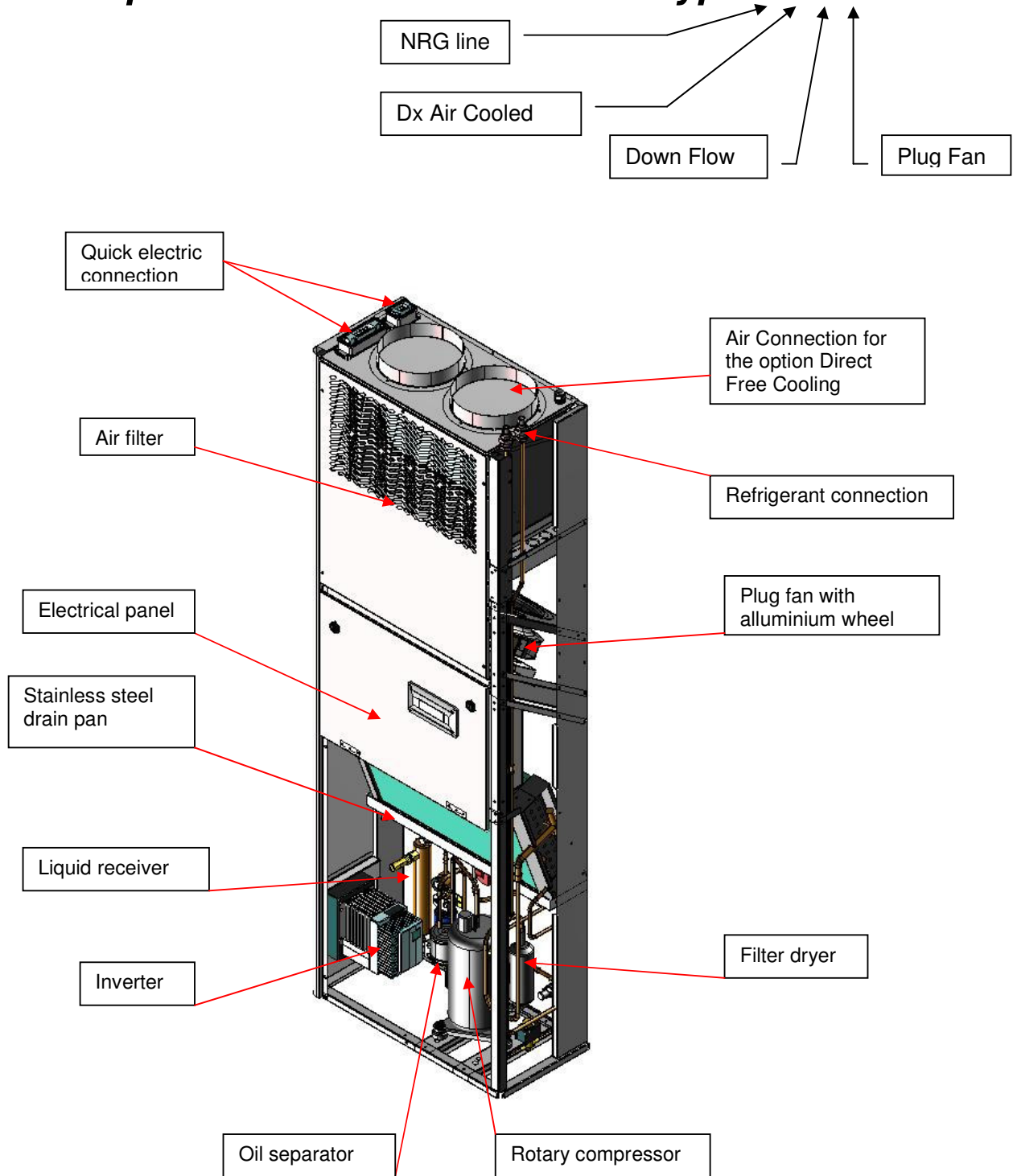



DIGIT

DIGIT Configuration

The NRG product range consists of 3 models with a cooling capacity from 3 to 33 kW in single circuit version. The units are available in different air flow configurations and in DX version according to the configuration DIGIT shown below. For the correct choice between possible configurations the electronic configuration software shall be applied.

DX Units :

N	A	D	R	0	2	6	1	1	2	3	4	5	6	7	8	9	10	11
----------	----------	----------	----------	----------	----------	----------	----------	----------	----------	----------	----------	----------	----------	----------	----------	----------	-----------	-----------

N : NRG series

DX Direct expansion units
A: remote air condensed units
W: water condensed units

Air Flow
D: Downflow
U: Upflow
X: Displacement

Fans
R: Radial fan with backward curved blades

Cooling capacity @ 80 Hz
KW

N° of refrigerating circuits
n°

Configuration		
1	Power supply	
	400V / 3 ph + N / 50Hz	3
	230V/1/50 (model 060)	
2	Control	
	Advanced (with local interface) – Carel pCO1	B
	Advanced (with local interface) – Graphic interface	C
3	Refrigerant	
	R410A	4
4	Fan	
	Brushless <i>EC Technology-Plug fan</i>	E
	Plug Fan standard motor	S
5	Humidifier	
	No	0
	Dehumidification	4
	Dehumidification + steam humidifier (model 130, 261 only)	5
6	Electrical Heaters	
	No	0
	Yes	F
7	Re-Heating system	
	No	0
	Hot gas coil modulating On/Off (Special) (model 130, 261)	4
	Hot gas coil modulating (only advanced control) (Special) (model 130, 261)	5
	Hot water coil with 0-10V signal activated valve (Special) (model 130, 261)	7
8	Air filtration	
	G3 (standard)	0
	G4	H
	G3 + clogged filter sensor	I
	G4 + clogged filter sensor	L
	F5	P
	F5 + clogged filter sensor	Q
9	Condensing control	
	No	0
	Mod. fan speed control with mcb (advanced)	5
	Mod. fan speed control with mcb for double circuits	6
	Flooding technology with back pressure valve (Special)	7
10	Packaging	
	Standard	0
	Wooden crate with cardboard	M
	Seaworthy	N
11	Special	
	Standard	0
	Special	S



Main characteristics

NRG Units

NRG self-contained units are specially designed for installation in technological environments with very high thermal loads such as computer rooms (especially blade server rooms), laboratories, where high modulation capacity of AC devices is required: in extreme density environments, the operating cooling capacity is normally much less than the design value and "modulating" units should be used. NRG units represent the state of the art between technology and design as known from all HiRef S.p.A. products. Thanks to their elevated specific capacity, from 29.7 to 41.6 KW/m² of footprint, NRG can be installed also in offices where people are working. The depth, from 300mm (NRG 060) to 795mm (NRG 261), allows to pass through standard doors and furthermore the innovative design and the high tech selected colours make NRG units complementary to the last generation of IT devices. All panels are made in galvanized steel with powder coated finish for an outstanding quality level. The internal design of the units is made to achieve the best efficiency and reliability and at the same time to do not lose accessibility: all components, including re-heaters, fans, compressors, valve, steam pipes, etc. can be maintained from the front. Additionally the front doors are dismountable in just a few seconds thanks to an innovative hinge: an important advantage when units are installed in narrow corridors. The exclusive use of primary brand components and a fully integrated development process (CAD+CAM, CAE) stands for highest possible quality level regarding efficiency, reliability, maintenance time, pre and after sales support. In NRG units, the inverter technology compressors is used. This characteristic allows the following advantages:

- Highest COP at partial load;
- Increasing in reliability;
- Stepless modulation between 25% and 100% (30÷120 Hz)
- Quick reaction against heat load variation (only 15 second to regulate the units from the min to the max refrigerant capacity, which is faster than a water 3-way-valves);
- Very low noise at partial load [-4dB];
- Compressor management fully integrated with indoor air flow, EEV and remote condenser management;
- Possibility to combine with direct and indirect free cooling (model 130, 261 only)

Frame

NRG units are designed with a self-supporting frame and all components (sheet metal, e-panel, piping, coils)

- Finned coil heat exchanger: the know-how of the development and production of this "FCHE" is

are produced in-house, using sophisticated computer driven machines and special tools. All sheet metals are galvanized and all external panels are powder coated in RAL 7016 colour giving the units an image and the quality like the last generation of IT devices. The units are completely closed and only a frontal access is necessary. Nevertheless it is also possible to have side access for any additional need. The shape of the units is characterized by rounded edges with variable radius: this feature is obtained by using special manufacturing tools and gives both - a good aesthetic - and an advantage to prevent injuries. The compressor compartment is separated from the air flow (except model 060) and a special internal design allows to simply dismount the upper part of it guaranteeing an insuperable accessibility to all refrigerating components. All fixing elements are made in stainless steel or in non corroding materials. The drain pan is made of stainless steel in order to ensure long life-time operation without damages.

All panels are thermally insulated with a polyurethane foam class 1 according UL 94 norms: this material, thanks to the open cells, gives excellent performance in sound absorption. Optional sandwich panels are available: in this case mineral fibre layers are closed between the panel and a second sheet of metal, giving a maximum in terms of internal cleaning and resistance against fire. The sound insulation of sandwich panels is better than the standard solution, but the internal reflected sound power increases the Lw on delivery side (+2dB).

Refrigerating circuit

The entire refrigerating circuit is assembled in HiRef's proper workshop, including all pipe work, using only primary brand for components. The workers involved in the welding and pipe work process are qualified by a third part according CEE 97/23 PED directive: necessary to underline that this qualification for workers was not request, but it was HiRef's decision taking care about the quality and -in general- for the customer 's satisfaction. The DX units are present in single circuit execution and are pre-charged with dry nitrogen for "A", "D" or with R410A refrigerant for "W", "F", "Z", "Q" versions.

- Compressors: on NRG units only primary brand compressors with special execution for inverter application motor, are installed. In the model 261 and 130 a Scroll compressors are used, in model 060 a rolling piston one.

within the Galletti Group. All coils are made by using a 25 x 21,65 mm geometry in combination with 8 mm copper pipes and aluminium fins of 0,10 mm thickness. The expanding process to ensure



High Technology in Refrigeration Devices

perfect contact between pipes and fins is one of the most critical points and it is 100% monitored in the whole production process. Design criteria in our R&D department and our laboratories are summarized in 4 main characteristics:

- Reduction of pressure drop by using a large front surface
- Hydrophilic treatment of the fins in order to allow a film condensation in dehumidification operation (typical angle water/aluminium <math><10^\circ</math>)
- Reduction of the vertical height to avoid big thickness in water film and - in consequence - the possibility to operate with high air volume and high r.h. without dragging out of water (especially in down flow units).
- Special corrugated fins increase the heat transfer coefficient air side in order to improve the SHR.

Looking into advantages of spare parts: one same coil is used for both up and down flow units.

The copper thickness and the number of the circuits are design for the highest efficiency and reliability using R410A.

- **Remote condensers:** coils are made using the 25 x 21,65 mm geometry in combination with 9,52 mm copper grooved pipes and aluminium louvered fins with 0,10 mm thickness: the combination of this technologies allows the maximum reduction in internal volume and - in consequence - a reduction of the refrigerant charge. The adopted fans are only with external rotor motor, in 4 or 6 poles execution, depending on the selected sound power level: in the catalogue two selections are already available, but special requests can be followed by the HiRef R&D department. The panels are made in galvanized precoated steel. Special feet for horizontal installation with vertical airflow are available for the whole range (optional). The copper thickness and the number of the circuits are design for the highest efficiency and reliability using R410A.

Looking to the destination of such units, four different type of condensing controls are optional available:

- Modulating fan speed installed in the CCAC => down to -15°C
- Flooding technology in addition to the fan speed control for temperatures below -15° and down to -30°C. This last option will be supplied as a kit including liquid receiver, back pressure valve, safety valve, protection cabinet and has to be installed on site just close to the condensing unit.

- **Refrigerating components:**

- Filter with molecular sieve and activated alumina.
- Sight glass with humidity indication.
- Electronic expansion valve for insuperable performances in middle and winter season: the pay back of the solution in north European countries is less than 1 Year. This solution is also required because of the modulating capacity.
- Liquid receiver according CEE 97/23 PED directive
- HP pressostat with manual reset according cat. IV CEE 97/23 PED.
- LP pressostat with automatic reset and delayed time during start up.
- Schrader valves for maintenance and or controls.

- During the dehumidification phase, The mP closes the EVV valve in order to decrease the evaporating temperature under the dew point temperature, to increase the latent percentage.

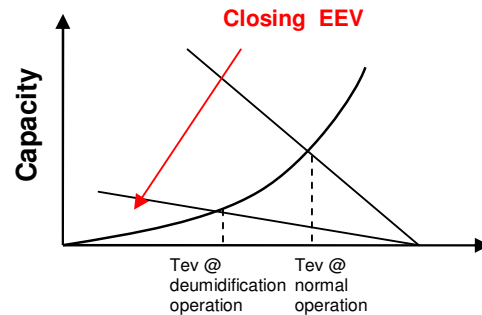

Electrical panel & components

- **Electrical panel:** fully contained in the unit it is designed according CEE directives 72/23, 89/336 and related norms. The possibility to have access to the e-panel opening the doors is needed: with open doors the protection still remains IP 30 thanks to a protecting transparent plastic panel in front of the components. All remote signals are @ very low voltage 24 Vac by means of a safety transformer. All e-panels have an air circulation system in order to keep the inside T under control when the unit is in operation. All connected loads are protected with automatic switches in addition to those already present inside the compressors and fans. All three phase units are standard equipped with a phase sequence relay: this device checks the sequence of the phases avoiding the start of the compressors in the wrong direction.

- **Microprocessor:**
- Advanced – Carel serie pCO1 in combination with the semigraphic pGD Display. For this control the



High Technology in Refrigeration Devices

HiRef Software Development Team is prepared to customize software according to customer specifications.

The main functions are summarised in:

- o Input of main parameters by means of the keyboard.
- o Displaying of operating conditions, alarms, devices
- o Switching on/off or modulating (3 way valve, humidifier) resources to keep constant the environment parameters.
- o Modulating the three way valve for hot water reheating (option)
- o Activating-deactivating the solenoid valve for hot gas reheating in DX version only (option)
- o Modulating the humidifier capacity
- o Activating the different steps in el. heating (option)
- o Alarm management
 - High / low ambient T
 - High / low Pressure refrigerant side
 - Air Flow
 - Dirty filters
 - E-heating
 - Humidifier general alarm
- o Management of maximum compressor startups.
- o Serial communications (optional) RS232 o RS485.
- o Control of the compressor speed.

Remote control and connection to BMS are possible as all mP are able to be connected in serial communication (the HSD [HiRef Software Development Team] is ready to support customers in system integration).

Interconnectivity is every day more a must :

- o Serial ports
 - RS232
 - RS485
- o Modem GSM: check with your local provider for the right contract for the SIM card. After activation, NRG units are ready for a stand alone bidirectional communication
- o Protocols
 - Carel [Built In]
 - Modbus®
 - LonWorks® [option to be selected at unit's ordering]
 - BACnet™ [External gateway]
 - TCP-IP[External gateway]
 - pCOWEB [Ethernet connector, SNMP protocol]
 - TREND® [option to be selected at unit's ordering]

Aeraulic section

Fans for all versions are radial type direct driven in combination with 4 poles motors with three phase power supply. Fans are statically and dynamically balanced ensuring a drastic reduction in noise and vibrations. NADR 261 and 130 models are equipped with EC fans with brushless motors (optional): this technology allows to reduce energy consumption mainly at partial load and allows to maintain the air flow independently from external conditions. The air circuit is completed with an air flow switch that checks fan's faulty situation.

Automatic air flow control option [mod. 130-261]

Air differential pressure sensor

Inside of the electrical panel is installed an air differential pressure sensor, to measure **the nozzle pressure drop dP**.

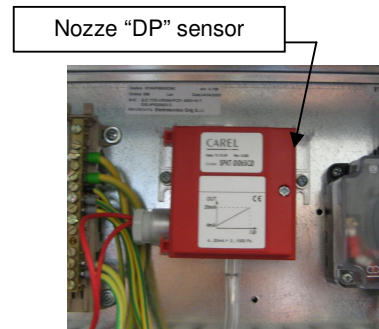

Using this value is possible to calculate the air flow and to regulate the fan speed (0-10V) to obtain the desired air flow (Air flow setpoint).

Air flow setpoint setting

To configure the air flow setpoint is necessary to enter in the setpoint menu and press DOWN to reach the screen S2. Then press ENTER and UP or DOWN to change the value: only step of 250 m3/h are possible.

```

m_select_air
+-----+
|Air flow      S2|
| setpoint: 7000 m3/h|
|               |
+-----+

```

Operating air differential pressure and related air flow

To see the actual air differential pressure (**Nozzle differential pressure**) and the actual air flow is necessary to enter in the Input/Output menu, and press DOWN to reach the screen .



High Technology in Refrigeration Devices

```

m_synoptic3b
+-----+
|Analog inputs: I2a|
|Coil temp: 000.0°C|
|Diff.press.:000.0 Pa|
|Air flow: 00000 m3/h|
+-----+
  
```

Important note

The automatic flow control is made using a PI (proportional + integral) regulation. The regulation is set with parameter to grant the stability of the system. Please take in account that the mean time to reach the stable value is 5-10 minutes.

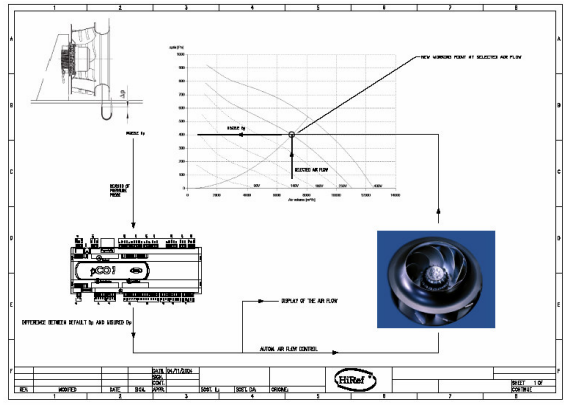

$$v_1 \times S_1 = v_2 \times S_2$$

(same air flow through the two sections)

for NRG units the ratio $S_2/S_1 = 0.17$ so that combining both the equations, the influence of the V_1 is negligible

$$\frac{p_1 - p_2}{\rho} = \frac{v_2^2}{2} \times \left(1 - \left(\frac{S_2}{S_1} \right)^2 \right) \Rightarrow$$

$$v_2 \cong \sqrt{\frac{2 \times (p_1 - p_2)}{\rho}} \Rightarrow \text{Air Flow} = S_2 \times V_2$$

Air Filter

The filters are positioned on the Top (Down Flow) or just in front of the coil (Up flow) and are made in synthetic material with metallic frame. Filtration efficiency is G4 according CEN EN 779. To exchange the filter, simply open the door(s) and remove it. As an option in the same dimension it is possible to install up to F5 filters, without any modification on the ventilation. For a higher filtration efficiency up to F9, an external plenum is needed. In this case a G4 filter will be part of the option as a pre-filter. With up flow units the High filtration plenum is positioned on the discharge side.

Humidifier

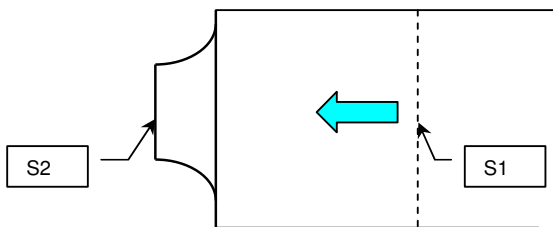

- S2 = Nozzle restricted section
- S1 = Unit's internal sec
- P = Air Pressure
- V = Air speed
- ρ = Air density

Note: the following calculation doesn't consider the friction and the flow coefficient of the nozzle, which are instead considered into the formulae memorized into the mP

$$\frac{p_1}{\rho} + \frac{v_1^2}{2} = \frac{p_2}{\rho} + \frac{v_2^2}{2} \quad \text{Bernoulli Principle ;}$$



The steam humidifier is fully controlled by the mP as well as all operating parameters like water level, water conductivity, current through electrodes. Fixing the tension, the current and obviously the steam capacity depend from the water conductivity and the water level: the algorithm mixing all parameters ensures the right steam production avoiding at the same time foam grooving into the cylinder. After a certain period - depending on the water characteristics- the cylinder has



High Technology in Refrigeration Devices

to be replaced by a new one: an European average is 3 cylinders / Year for full time operation.

Description of Immersed Electrode Humidifiers:

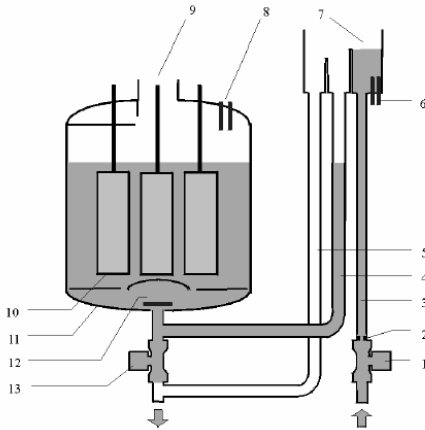

- N. Description
- 1 Fill solenoid valve
 - 2 Flow rate limiting device
 - 3 Supply pipe
 - 4 Fill pipe
 - 5 Overflow pipe
 - 6 Conductivity measuring Electrodes
 - 7 Fill tank – overflow device
 - 8 High level electrodes
 - 9 Steam outlet
 - 10 Electrodes
 - 11 Cylinder casing
 - 12 Bottom filter
 - 13 Drain solenoid valve

Important water supply characteristic:

For this units there is three humidifiers option:

- medium-low conductivity
- normal-high conductivity
- high conductivity.

In the Appendix “A” there are the supply water limit values to choose between the three option.

Humidity control

NRG units can be supplied with Humidity sensor (option). For an independent control between T and r.h. it is necessary to adopt one of the reheating possibilities (options)

- Electrical reheating.
- Hot Water with 3 way modulating valve (model 261, 130 only).
- Hot gas reheating: this solution is for DX version and - looking to energy consumption – it is made

with zero extra energy: this option is available in On/Off version or in modulating version for more precision in parameters control. The reheating coil design criteria allows to have bigger heating than sensible cooling capacity allowing to dehumidify even when there are no thermal loads inside (model 261, 130 only).

Fresh air kit

Fresh air kit consists of a flexible pipe and a cartridge G3 filter and under normal conditions ensures roughly 150 m³/h independently from the unit's model. In down flow units the filter is located in the fans section and before removing the filter it is necessary to stop the unit and to remove the sheet metal of the fan's compartment. In up flow units an additional booster fan is provided to ensure roughly 80 m³/h for all models and the relative filter is located just close to the main filter.

Plenum Kit

Suction/delivery plenum with 300mm and 500mm height are available. In case of down flow units such plenums can be equipped with silencer cartridges, damper section for Direct Free-Cooling and high efficiency filters. In case of up flow units the delivery plenum can be fitted with aluminium grills for frontal air discharge.

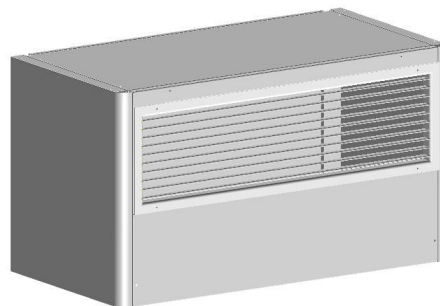

Base Frames/Floorstands

Made in galvanized steel, are available in three different heights 300 - 500 - 800 mm, with excursion +/- 25mm.

Electrical Heaters

Made in aluminium with a large surface for keeping the lowest possible surface temperature (less than 130 °C), and is working in a 3 steps operation mode. Each element is provided with an independent safety thermostat. Despite the very small depth of the unit, the elements are mounted in a special rail in order to



High Technology in Refrigeration Devices

extract them from the front of the units. This is possible with all NRG models, UP and Down flow.

Before any maintenance on electrical heaters, disconnect the units from power supply and wait min. 30 minutes, allowing the temperature to decrease.



Application Field

NRG units are designed for indoor installation in technological environments but have been tested also under extreme conditions, typical for far East markets: the indoor temperature limits are between 20°C and 32°C with a r.h up to 55% on the whole range. Practically indoor conditions don't play any role for a reliable operation.

The application field for DX units -water or air condensed- is shown in the relative diagrams:

▪ Water condensed:

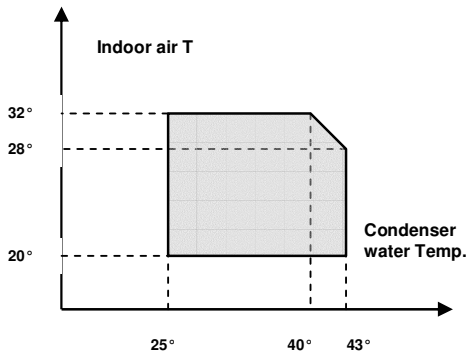

For water T under 25°C condensing control valve is needed (option):

- ❑ Using a 2 way modulating valve water side. The valve is installed in the inlet piping to avoid that in case of broken pipe refrigerant side, a lot of water could flow into the system.
- ❑ Using the flooding technology. In this case there are no influence on water flow, but just a flooding of heat exchanging surface by means of a constant back pressure valve and a large liquid receiver.

▪ Air condensed:

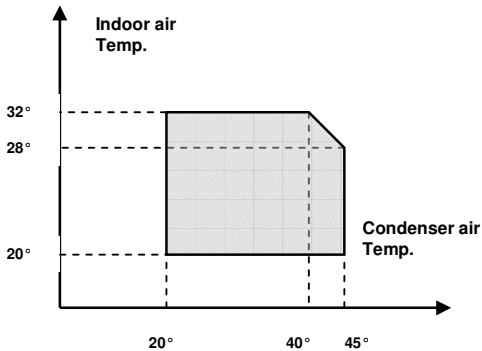

If extended application ranges are needed, please contact the R&D department or your local dealer.

For air temperatures below 20 °C, a condensing control is necessary to ensure enough pressure drops across the expansion device. For T below -15° and up to -30°C, a flooding device has to be added in order to flood the condenser internal surface allowing the right condensing T even in case of strong and cold wind T. This device is shipped as a kit consisting of a back pressure valve, a receiver, a safety valve and mounting instructions: the installation is very simple and has to be done just close to the condensing unit at bottom side.

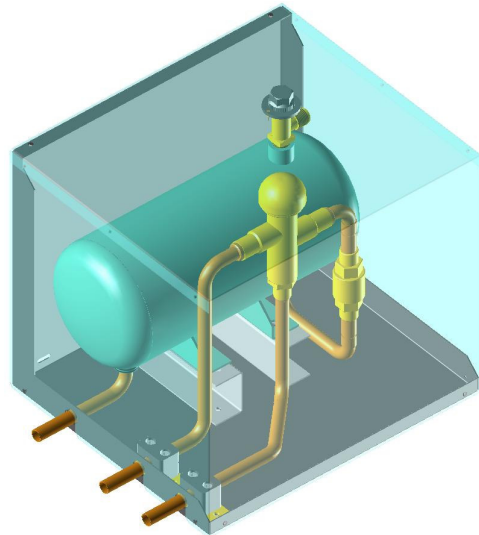

Compressors oil heaters

The "Oil" figure illustrates a specific property [Charles' Law] of gases, which are more soluble in liquids as the pressure increases but less soluble as the temperature increases: if the oil in the sump is held at a constant pressure, an increase in temperature will significantly reduce the amount of refrigerant dissolved in it, thus ensuring that the lubricating function desired is maintained. The problem of inadequate lubrication occurs if the crankcase is not duly heated, above all after seasonal interruptions when, due to the suction effect of the compressor, there is an abrupt drop in pressure inside the sump, which results in considerable evaporation of the refrigerant previously dissolved in the oil. If heating elements were not installed, this phenomenon would cause two problems

- ❑ Dilution of the oil, hence inadequate lubrication



High Technology in Refrigeration Devices

- Migration of the oil toward the cooling circuit due to the dragging effect of the refrigerant.

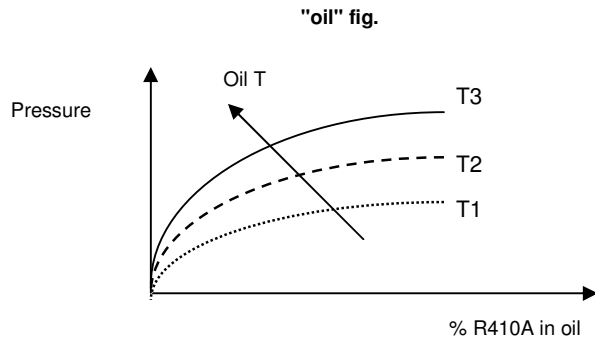

Electrical heaters are necessary when units are put out of order for longer periods and remain at a temperature below 15°C. In case of crankcase heaters, please switch it on at least 12 hours before compressor start up.

PVE OIL characteristic

Polyvinylether (PVE) as innovative refrigeration oil for HFC refrigerant systems. The characteristics of PVE are non-hydrolysis nature, superior lubricity, solubility with process fluid and miscibility with HFC refrigerant.

These performances directly or indirectly contribute to the total cost down of systems.

Compared PVE with POE oils, the next considerations can be done:

- Since PVE is a polymer even if the viscosity or miscibility is changed, the basic characteristics are the same, in case of POE, since POE is monomer when the viscosity or miscibility changes, different raw materials are required and the basic characteristics are different; therefore, when you use different viscosity or miscibility of POE, you have to start the evaluation from the beginning, but not for PVE.
- Generally speaking, ether has low electric resistivity.

Application limits short table

- DX: synthetic non dangerous non flammable refrigerant HFC R410A
- Max P refrigerant cycle HP side = 42 bar-r
- Max piping T HP side = 125 °C
- Max P refrigerant cycle LP side= 22 bar-r (*)
- Power supply: +/- 10% to the nominal value
- **Max storage T** = + 50 °C
- Minimum storage T = - 10 °C
- Max r.h. during storage = 85%

(*) This value influences the maximum storage T for units with a closed refrigerant circuits, like "W" water cooled, "F" free cooling, "Q" Dual cooling" units.



Technical section

Thermodynamics

Refrigerant. In NRG units R410A is used. This refrigerant is a mixture of R32 and R125 (50% - 50%), nearly azeotropic. Its behaviour is much similar to that one of a pure fluid: in fact it introduces a glide approximately 0,1°C. Its main characteristics are the elevated pressure of exercise and one consequent elevated density of the vapour. It introduces, moreover, an elevated volumetric effect refrigerator and a remarkable advantage in terms of performances. The comparison between various fluid as far as the attitude to the thermal exchange it must be made to parity of the penalization induced from the pressure drops on the profiles of temperature and therefore with various specific mass flow from fluid to fluid, also to parity of cooling capacity.

Compressor. The compressors used in NRG units , combined to inverter, are able to modulate the cooling capacity varying their frequency.

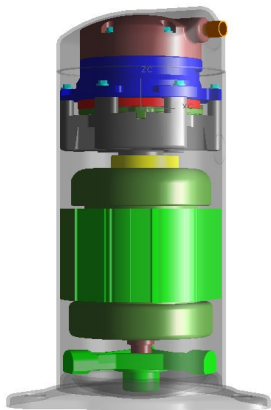

A temperature transmitter reads the indoor conditions and the mP manages the inverter voltage output to modulate the frequency of the compressor as shown in the next figure:

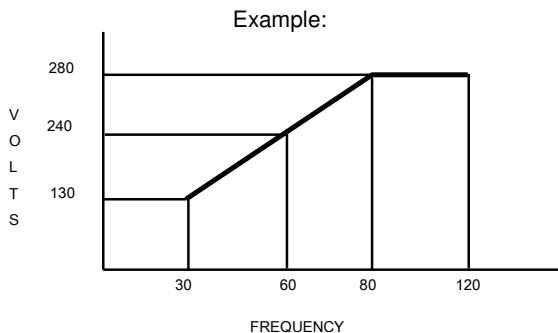

Frequency and voltage are coordinate to maintain the torque and the current under control.

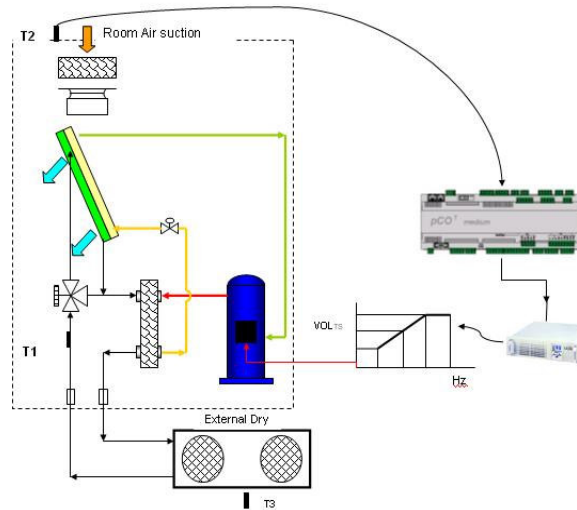

Expansion Valves. The expansion valve is just a mass flow regulator ensuring the right flow checking the superheating at the evaporator outlet. The mass flow depends mainly from the % of opening and from the delta pressure available across the valve. Mechanical valves have a very little modulating capacity and to ensure the mass flow, a significant Delta P across it has to be maintained. NRG uses an electronic driven valves that ensures a big modulation capacity thanks to the big stroke of their shutter: with this solution it is possible to reduce the minimum Delta P across the valve, reducing -in consequence- the condensing T during middle and winter seasons. The minimum allowed condensing T (Dew Point) is 28°C due to scroll compressor mechanical limits.

In this periods the reduction in energy consumption reaches 51 % guaranteeing a shortest payback time for this solution: HiRef R&D department can easily calculate it for specific thermal load and outside T profiles.





High Technology in Refrigeration Devices

The simple schema shows how the valve is managed: a pressure transmitter is reading the evaporating pressure and a T sensor is measuring the Refrigerant T. The mP calculates the superheating and - using special algorithms [part of them patented by HiRef S.p.A. (pat. nr. BO2002A000785 ITA) - drives the opening/closing of the valve by means of a stepper motor.

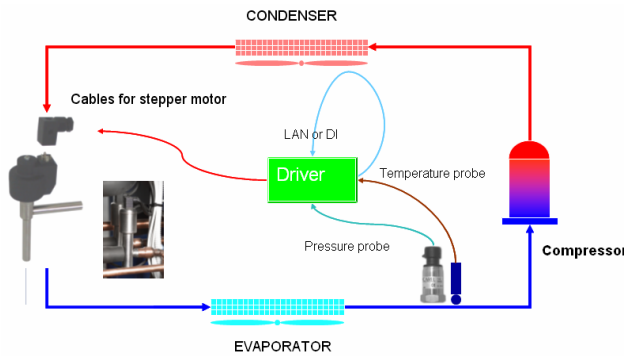



Performances Tables @ 24°/50% inside conditions

The use of the inverter gives the possibility to increase the evaporating temperature during the partial load. High evaporating temperature guarantee high performance efficiency and SHR. *The performances are given considering the unit in combination with the suggested remoter condenser and with an outside air T of 35 °C.*

NADR 261			
Frequency	Cooling Capacity	Sensible Capacity	SHR
[Hz]	[kW]	[kW]	[-]
30	12,40	12,40	1,00
40	14,90	14,90	1,00
50	17,40	17,40	1,00
60	19,90	19,90	1,00
70	22,30	22,30	1,00
80	24,60	23,20	0,94
90	26,90	24,30	0,90
100	29,20	25,40	0,87
110	31,50	26,20	0,83

■ With option enlarged driver

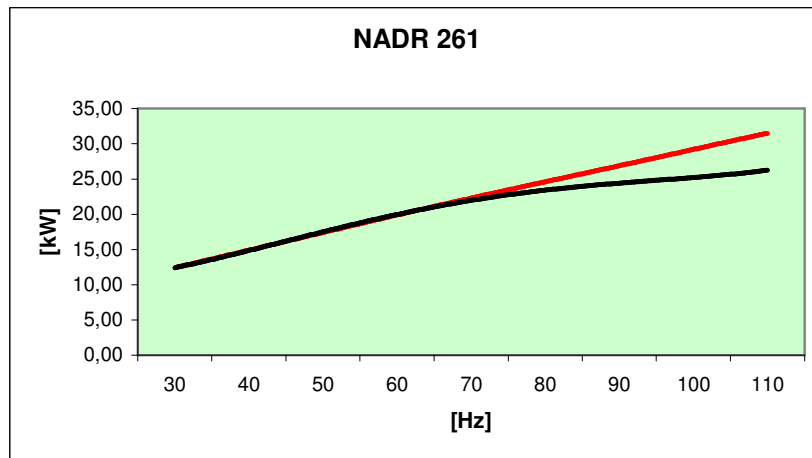

— sensible capacity
 — total capacity



High Technology in Refrigeration Devices

The performances are given considering the unit in combination with the suggested remoter condenser and with an outside air T of 35 °C

NADR 130			
Frequency	Cooling Capacity	Sensible Capacity	SHR
[Hz]	[kW]	[kW]	[-]
30	6,30	6,30	1,00
40	7,80	7,80	1,00
50	9,30	9,30	1,00
60	10,80	10,80	1,00
70	12,40	12,40	1,00
80	12,90	12,90	1,00
90	13,40	13,40	1,00
100	13,90	13,60	0,98
110	14,50	13,90	0,96

 With option enlarged driver

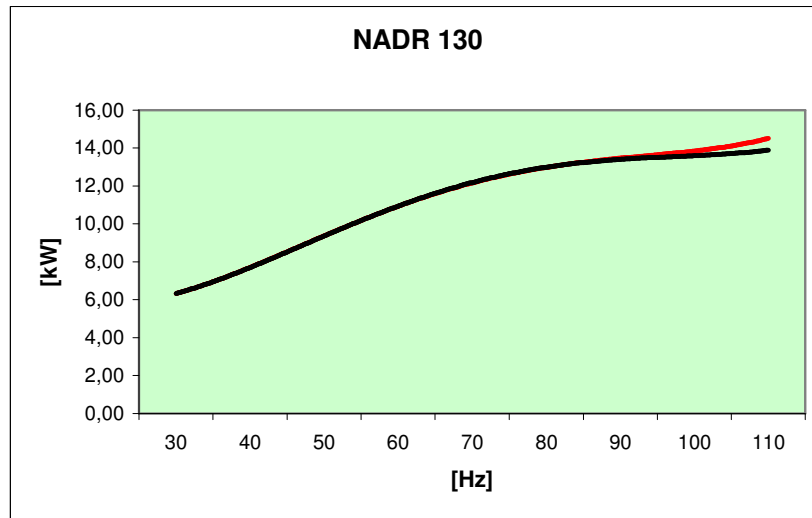

— sensible capacity
 — total capacity





High Technology in Refrigeration Devices

The performances are given considering the unit in combination with the suggested remoter condenser and with an outside air T of 35°C

NADR 060			
Frequency	Cooling Capacity	Sensible Capacity	SHR
[Hz]	[kW]	[kW]	[-]
30	2,70	2,70	1,00
40	3,40	3,40	1,00
50	4,20	4,20	1,00
60	4,90	4,40	0,90
70	5,70	4,70	0,82
80	6,20	4,90	0,79
90	6,70	5,10	0,76
100	7,20	5,30	0,74
110	7,60	5,50	0,72

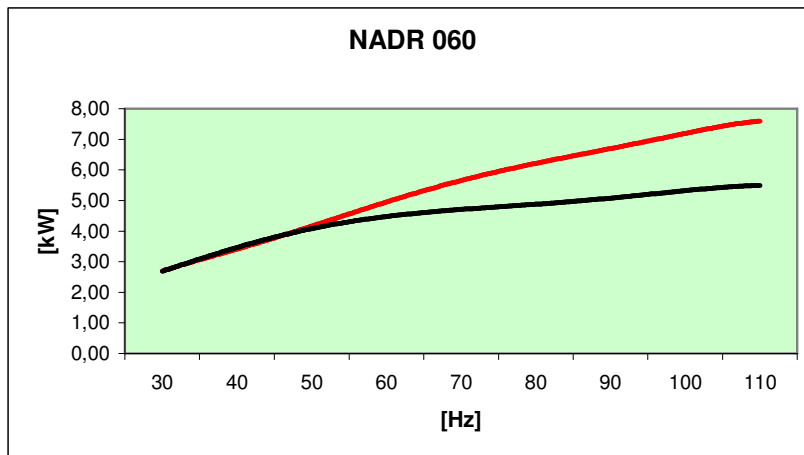
 With optional enlarged driver



 sensible capacity
 total capacity



Technical Data TREF NRG 261

		Min Speed (30 Hz)	Intermediate Speed (70 Hz)	Max Speed (120 Hz)
Air Flow	[m ³ /h]	7280	7280	7280
Compressor				
Type		Scroll	Scroll	Scroll
Total Cooling Capacity @ 24°C 50% UR - external air temperature 35°C	[kW]	12.4	22.3	31.5
Sensible Cooling Capacity @ 24°C 50% UR - external air temperature 35°C	[kW]	12.4	22.3	26.2
Power consumption	[kW]	2.75	6.0	11.8
Max rate of changing	[Hz/s]	6	6	6
Nominal Current	[A]	5.5	12.0	23.7
FLA	[A]	27.8	27.8	27.8
LRA	[A]	7.6	7.6	7.6
PVE Oil charge	[l]	2.3	2.3	2.3
Finned coil evaporator				
Front Surface	[m ²]	0.67	0.67	0.67
Geometry		25x22	25x22	25x22
Rows	[-]	5	5	5
Type of fins	[-]	Hydrophilic without silicates	Hydrophilic without silicates	Hydrophilic without silicates
Fin pitch	[mm]	2.1	2.1	2.1
SHR	[-]	1.00	1.00	0.83
Indoor fan				
Type		Plug EBM "EC" series	Plug EBM "EC" series	Plug EBM "EC" series
Type of fan motor		Brushless with Integrated electronic	Brushless with Integrated electronic	Brushless with Integrated electronic
Balancing quality		<= Q 6.3 according ISO 1940-1	<= Q 6.3 according ISO 1940-1	<= Q 6.3 according ISO 1940-1
Type of motor protection		IP 54 according EN 60529	IP 54 according EN 60529	IP 54 according EN 60529
Variable speed		Automatic Air Flow control	Automatic Air Flow control	Automatic Air Flow control
Power supply	[V-ph-Hz]	400/3+N/50	400/3+N/50	400/3+N/50
Number of fans		1	1	1
Fans absorbed current @ nominal air flow	[A]	1.2	1.2	1.2
Fans absorbed power @ nominal air flow	[W]	1200	1200	1200
AESP	[Pa]	30	30	30
AESP (maximum speed)	[Pa]	355	355	355
Air Filter				
Filtration		G4	G4	G4
Overall surface	[m ²]	2.20	2.20	2.20
Fire resistance class		1	1	1
Electrical heaters				
Total Heating Capacity	[kW]	6.4	6.4	6.4
N° of heaters		2	2	2
Material	[-]	Aluminium	Aluminium	Aluminium
Hot gas Reheating Coil				
Heating capacity	[kW]	18.1	18.1	18.5
Front Surface	[m ²]	0.65	0.65	0.65
Hot Water reheating coil				
Heating capacity @ 45/40° water T	[kW]	15,5	15,8	16,3
Front Surface	[m ²]	0.65	0.65	0.65
Water flow	[m ³ /h]	2.552	2.696	2.98
Water side pressure drop	[kPa]	15.6	18.2	25.3



High Technology in Refrigeration Devices

Water valve pressure drop	[kPa]	14.72	15.13	15.55
Internal volume	[dm3]	1.443	1.443	1.443
Humidifier				
Max theoretical capacity	[kg/h]	11.86	11.62	9.66
Effective capacity	[kg/h]	8	8	8
Absorbed power	[kW]	6	6	6
Frame				
H	[mm]	1998	1998	1998
L	[mm]	1010	1010	1010
D	[mm]	795	795	795
Weight	[kg]	394	394	394

 **With optional enlarged driver**



Technical Data TREF NRG 130

		Min Speed (30 Hz)	Intermediate Speed (70Hz)	Max Speed (110 Hz)
Air Flow	[m ³ /h]	4900	4900	4900
Compressor				
Type		Scroll	Scroll	Scroll
Total Cooling Capacity @ 24°C 50% UR - external air temperature 35°C	[kW]	6.3	12.4	14.5
Sensible Cooling Capacity @ 24°C 50% UR - external air temperature 35°C	[kW]	6.3	12.4	13.9
Power consumption	[kW]	1.65	3.33	5.1
Max rate of changing	[Hz/s]	6	6	6
Nominal Current	[A]	3.3	6.7	10.2
FLA	[A]	14.9	14.9	14.9
LRA	[A]	2.7	2.7	2.7
PVE Oil charge	[l]	0.75	0.75	0.75
Finned coil evaporator				
Front Surface	[m ²]	0.44	0.44	0.44
Geometry		25x22	25x22	25x22
Rows	[-]	4	4	4
Type of fins	[-]	Hydrophilic without silicates	Hydrophilic without silicates	Hydrophilic without silicates
Fin pitch	[mm]	1.8	1.8	1.8
SHR	[-]	1.00	1.00	0.96
Indoor fan				
Type		Plug EBM "EC" series	Plug EBM "EC" series	Plug EBM "EC" series
Type of fan motor		Brushless with Integrated electronic	Brushless with Integrated electronic	Brushless with Integrated electronic
Balancing quality		<= Q 6.3 according ISO 1940-1	<= Q 6.3 according ISO 1940-1	<= Q 6.3 according ISO 1940-1
Type of motor protection		IP 54 according EN 60529	IP 54 according EN 60529	IP 54 according EN 60529
Variable speed		Automatic Air Flow control	Automatic Air Flow control	Automatic Air Flow control
Power supply	[V-ph-Hz]	400/3+N/50	400/3+N/50	400/3+N/50
Number of fans		1	1	1
Fans absorbed current @ nominal air flow	[A]	0.8	0.8	0.8
Fans absorbed power @ nominal air flow	[W]	450	450	450
AESP	[Pa]	30	30	30
AESP (maximum speed)	[Pa]	250	250	250
Air Filter				
Filtration		G3	G3	G3
Overall surface	[m ²]	0.80	0.80	0.80
Fire resistance class		1	1	1
Electrical heaters				
Total Heating Capacity	[kW]	3.2	3.2	3.2
N° of heaters		2	2	2
Material	[-]	Aluminium	Aluminium	Aluminium
Hot gas Reheating Coil				
Heating capacity	[kW]	16.9	16.9	16.9
Front Surface	[m ²]	0.55	0.55	0.55
Hot Water reheating coil				
Heating capacity @ 45/40° water T	[kW]	11.8	11.8	11.8
Front Surface	[m ²]	0.55	0.55	0.55
Water flow	[m ³ /h]	1.847	1.847	1.847
Water side pressure drop	[kPa]	43.0	43.0	43.0



High Technology in Refrigeration Devices

Water valve pressure drop	[kPa]	13.0	13.0	13.0
Internal volume	[dm3]	1.312	1.312	1.312
Humidifier				
Max theoretical capacity	[kg/h]	10.09	10.09	10.09
Effective capacity	[kg/h]	3	3	3
Absorbed power	[kW]	2.25	2.25	2.25
Frame				
H	[mm]	1875	1875	1875
L	[mm]	900	900	900
D	[mm]	600	600	600
Weight	[kg]	282	282	282

 **With optional enlarged driver**



Technical Data TREF NRG 060

		Min Speed (30 Hz)	Intermediate Speed (70 Hz)	Max Speed (110 Hz)
Air Flow	[m ³ /h]	1350	1350	1350
Compressor				
Type		Rolling pistons	Rolling pistons	Rolling pistons
Total Cooling Capacity @ 24°C 50% UR - external air temperature 35°C	[kW]	2.7	5.7	7.6
Sensible Cooling Capacity @ 24°C 50% UR - external air temperature 35°C	[kW]	2.7	4.7	5.5
Power consumption	[kW]	1.0	2.0	3.2
Max rate of changing	[Hz/s]	6	6	6
Nominal Current	[A]	6.0	12.0	19.0
FLA	[A]	23.8	23.8	23.8
LRA	[A]	8.1	8.1	8.1
PVE Oil charge	[l]	0.6	0.6	0.6
Finned coil evaporator				
Front Surface	[m ²]	0.17	0.17	0.17
Geometry		25x21.65	25x21.65	25x21.65
Rows	[-]	4	4	4
Type of fins	[-]	Hydrophilic without silicates	Hydrophilic without	Hydrophilic without silicates
Fin pitch	[mm]	1.8	1.8	1.8
SHR	[-]	1.00	0.82	0.72
Indoor fan				
Type		Plug EBM	Plug EBM	Plug EBM
Type of fan motor		External rotor	External rotor	External rotor
Balancing quality		<= Q 6.3 according ISO 1940-1	<= Q 6.3 according	<= Q 6.3 according ISO 1940-1
Type of motor protection		IP 44 according EN 60529	IP 44 according EN	IP 44 according EN 60529
Variable speed		Stepless Manual setting	Stepless Manual setting	Stepless Manual setting
Power supply	[V-ph-Hz]	230/1/50	230/1/50	230/1/50
Number of fans		2	2	2
Fans absorbed current	[A]	1.1	1.1	1.1
Fans absorbed power	[W]	240	240	240
AESP	[Pa]	30	30	30
AESP (maximum speed)	[Pa]	227	227	227
Air Filter				
Filtration		G3	G3	G3
Overall surface	[m ²]	0.60	0.60	0.60
Fire resistance class		1	1	1
Electrical heaters				
Total Heating Capacity	[kW]	1.5	1.5	1.5
N° of heaters		1	1	1
Material	[-]	Aluminium	Aluminium	Aluminium
Frame				
H	[mm]	1800	1800	1800
L	[mm]	600	600	600
D	[mm]	300	300	300
Weight	[kg]	147	147	147

With optional enlarged driver



Remote Condenser Technical Data Collection

Remote Condenser – Standard Execution - SHVN

SHVN		12/8 – Q*	20/4 – Q*	40/9 – Q*
NRG models	Mod.	060	130	261
Power supply	V/Ph/Hz	230/1/50	230/1/50	230/1/50
Air flow	m3/h	3000	4600	9200
Absorbed power	W	270	360	720
Absorbed current	A	1.2	1.7	3.4
Fans	Nr.	2	2	4
	mm	330	350	350
Sound pressure level in f.f. @ 10 m	dB(A)	41	43	46
Dimensions	L mm	1057	1294	1298
[vertical air flow]	D mm	500	600	1150
	H mm	600	763	863
Dimensions	L mm	1057	1264	1298
[horizontal air flow]	D mm	305	363	363
	H mm	463	573	1125
Weight	kg	25	40	77

() Special condenser design for R410A*

Remote Condenser – Low Noise Execution - SHVS

SHVS		13/5– Q*	20/2– Q*	40/5– Q*
NRG models	Mod.	060	130	261
Power supply	V/Ph/Hz	230/1/50	230/1/50	230/1/50
Air flow	m3/h	2600	3900	7800
Absorbed power	W	140	210	420
Absorbed current	A	0.7	1.0	2.0
Fans	Nr.	2	3	6
	mm	350	350	350
Sound pressure level in f.f. @ 10 m	dB(A)	33	35	38
Dimensions	L mm	1294	1294	1853
[vertical air flow]	D mm	600	600	1150
	H mm	752	752	852
Dimensions	L mm	1294	1853	1853
[horizontal air flow]	D mm	352	352	352
	H mm	573	573	1125
Weight	kg	36	52	100

() Special condenser design for R410A*



Refrigerant Pipes

On site piping has to be installed by professional workers using only CUB quality copper pipes. Take care in use of nitrogen during all brazing operations in order to avoid humidity and dirty in pipes.

Refrigerant		R410A	R410A	R410A
Model		NRG 261	NRG 130	NRG 060
HP horizontal Gas line	[mm] [Inch]	15.88 5/8	12.70 1/2	9.53 3/8
Hp vertical Gas line	[mm] [Inch]	12.70 1/2	9.53 3/8	7.94 5/16
Liquid line	[mm] [Inch]	12.70 1/2	9.53 3/8	9.53 3/8

Table up to 10 m of pipe length

The declared performances are calculated for a max lines length of 10m, in the next table, the absorbed compressor power and the cooling capacity variation percentage for 20m lines, are showed:

Model	NRG 261			NRG 130			NRG 060		
Frequency	30Hz	90Hz	110Hz	30Hz	90Hz	110Hz	30Hz	90Hz	110Hz
Cooling Capacity [%]	-0.43	-1.37	-1.30	-0.10	-1.05	-1.70	-0.10	-1.71	-2.86
Power Consumption [%]	+0.25	+1.59	+2.48	+0.54	+1.27	+1.72	+0.54	+2.35	+3.36

Standard Copper pipes

Diameter [mm]	Thickness [mm]	Minimum bending radius [mm]	System design pressure PS [bar]	PED Category	Max Copper σ [N/mm ²]	Real copper σ [N/mm ²]	Safety ratio
10	1	36	42	A3 P3	227	16.8	13.5
12	1	36	42	A3 P3	227	21.0	10.8
16	1	46	42	A3 P3	227	29.4	7.7
18	1	56	42	A3 P3	227	33.6	6.8
22	1,5	67	42	A3 P3	227	26.6	8.5
28	1,5	96	42	A3 P3	227	35.0	6.5
35	1.5	70	42	A3P3	227	44.8	5.0
42	1.5	84	42	A3P3	227	54.6	4.2
54	2.0	108	42	A3P3	227	52.5	4.3



High Technology in Refrigeration Devices

Refrigerant Charge

The following table gives an idea of the total refrigerant charge: this should be used just as first reference but the right charge should be performed on site by a qualified installer .

Note: The NRG units as well as the remote condenser are shipped filled with nitrogen or dry air.

Model		NRG 261	NRG 130	NRG 060
Unit Charge	[kg]	3.080	2.190	1.210
Air Cooled Condenser Charge (standard unit)	[kg]	3.870	1.780	1.490
Air Cooled Condenser Charge (low noise unit)	[kg]	5.350	3.870	1.780
Charge for liquid line	[kg/m]	0.130	0.080	0.070

Note: approximated values ($\pm 20\%$), to be verified on site.



Appendix "A" : Supply water limit values for the immersed electrode humidifiers

			MEDIUM-LOW CONDUCTIVITY		NORMAL-HIGH CONDUCTIVITY		HIGH CONDUCTIVITY	
			MIN	MAX	MIN	MAX	MIN	MAX
Specific conductivity at 20 °C	σ_{20}	$\mu\text{S/cm}$	125	350	350	750	750	1250
Total dissolved solids	TDS	mg/l	(¹)	(¹)	(¹)	(¹)	(¹)	(¹)
Dry residue at 180 °C	R₁₈₀	mg/l	(¹)	(¹)	(¹)	(¹)	(¹)	(¹)
Hydrogen ion activity	pH	-	7	8.5	7	8.5	7	8.5
Total hardness	TH	mg/l CaCO ₃	-	200	150	400	150	400
Temporary hardness	TH	mg/l CaCO ₃	-	150	-	200	-	200
Chlorides		ppm Cl	-	20	-	30	-	30
Iron + Manganese		mg/l Fe+Mn	-	0.2	-	0.2	-	0.2
Silica		mg/l SiO ₂	-	20	-	20	-	20
Residual chlorine		mg/l Cl ⁻	-	0.2	-	0.2	-	0.2
Calcium sulphate		Mg/l CaSO ₄	-	60	-	100	-	100

(¹) Values depend on the specific conductivity; in general: TDS \cong 0.93 * σ_{20} ; R₁₈₀ \cong 0.65 * σ



Installation drawings NADR 261

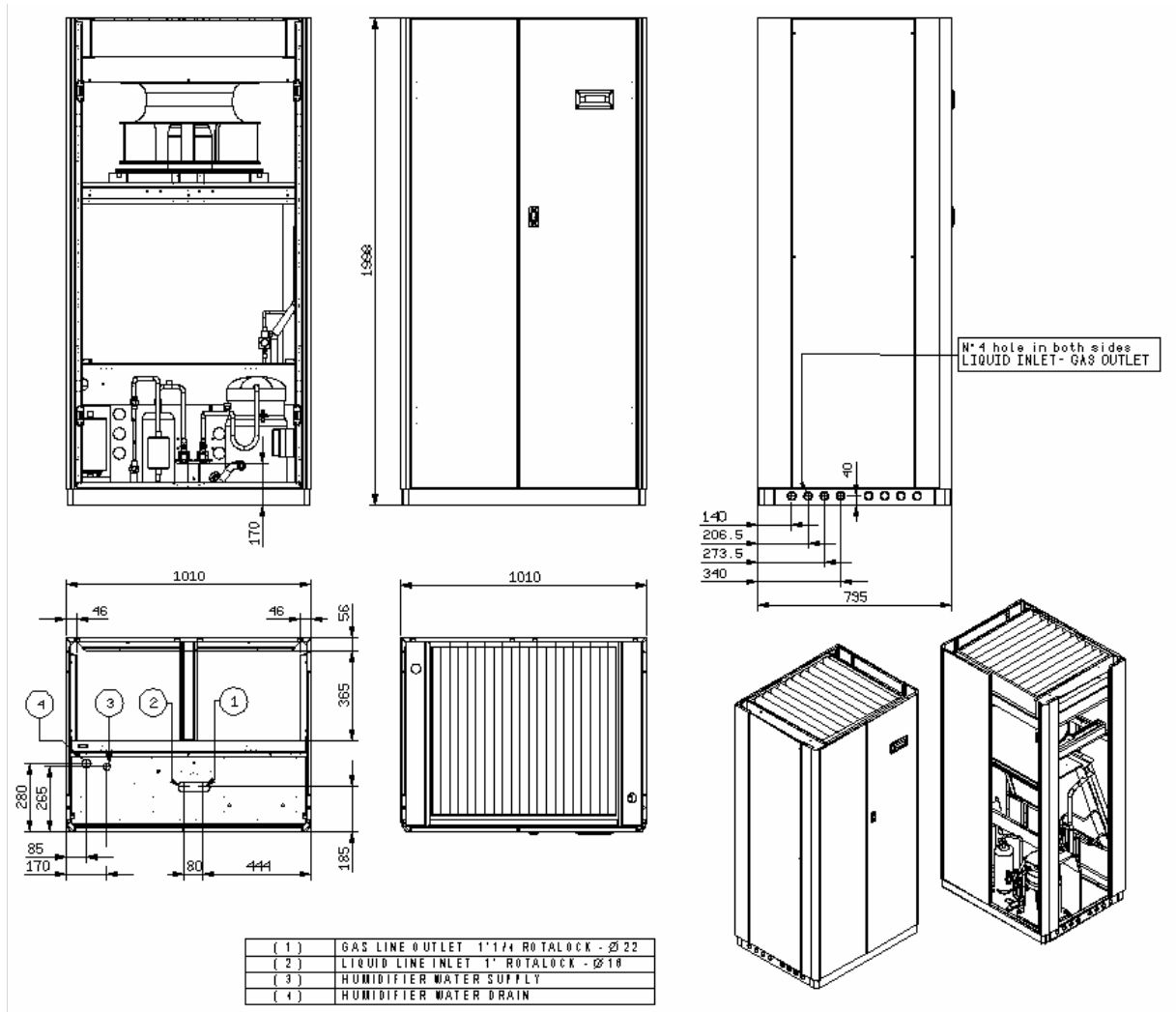



Installation drawings NADR 130

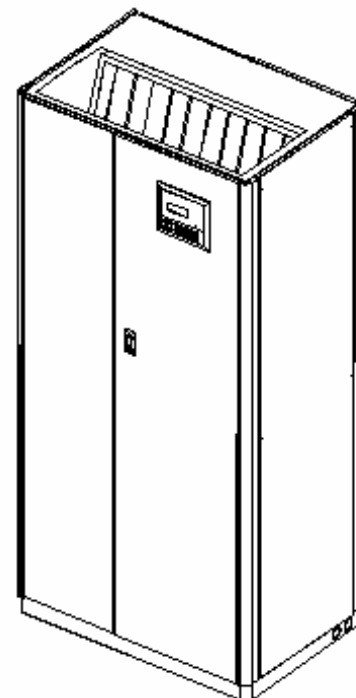
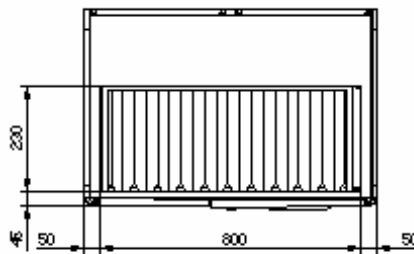
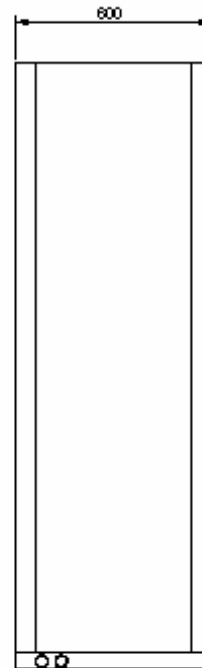
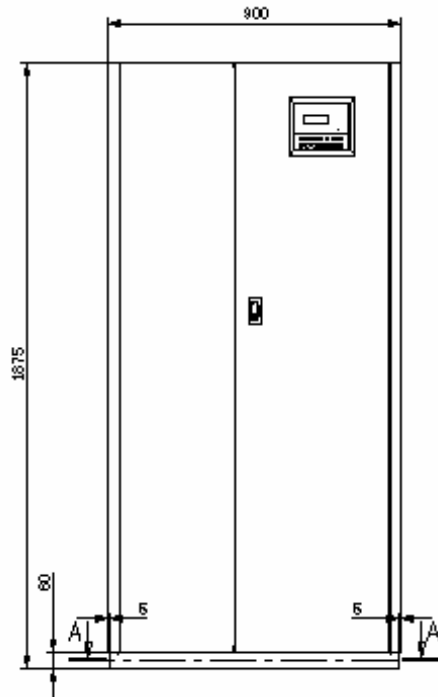

Section A-A

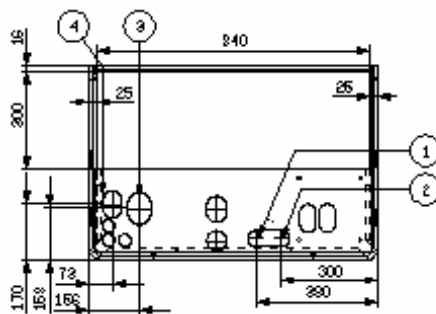

(1)	LIQUID LINE INLET 1" ROTALOCK \varnothing 1 2
(2)	GAS LINE OUTLET 1" ROTALOCK \varnothing 1 6
(3)	HUMIDIFIER WATER SUPPLY \varnothing 6
(4)	HUMIDIFIER WATER DRAIN \varnothing 2 5



High Technology in Refrigeration Devices

Installation drawings NADR 060

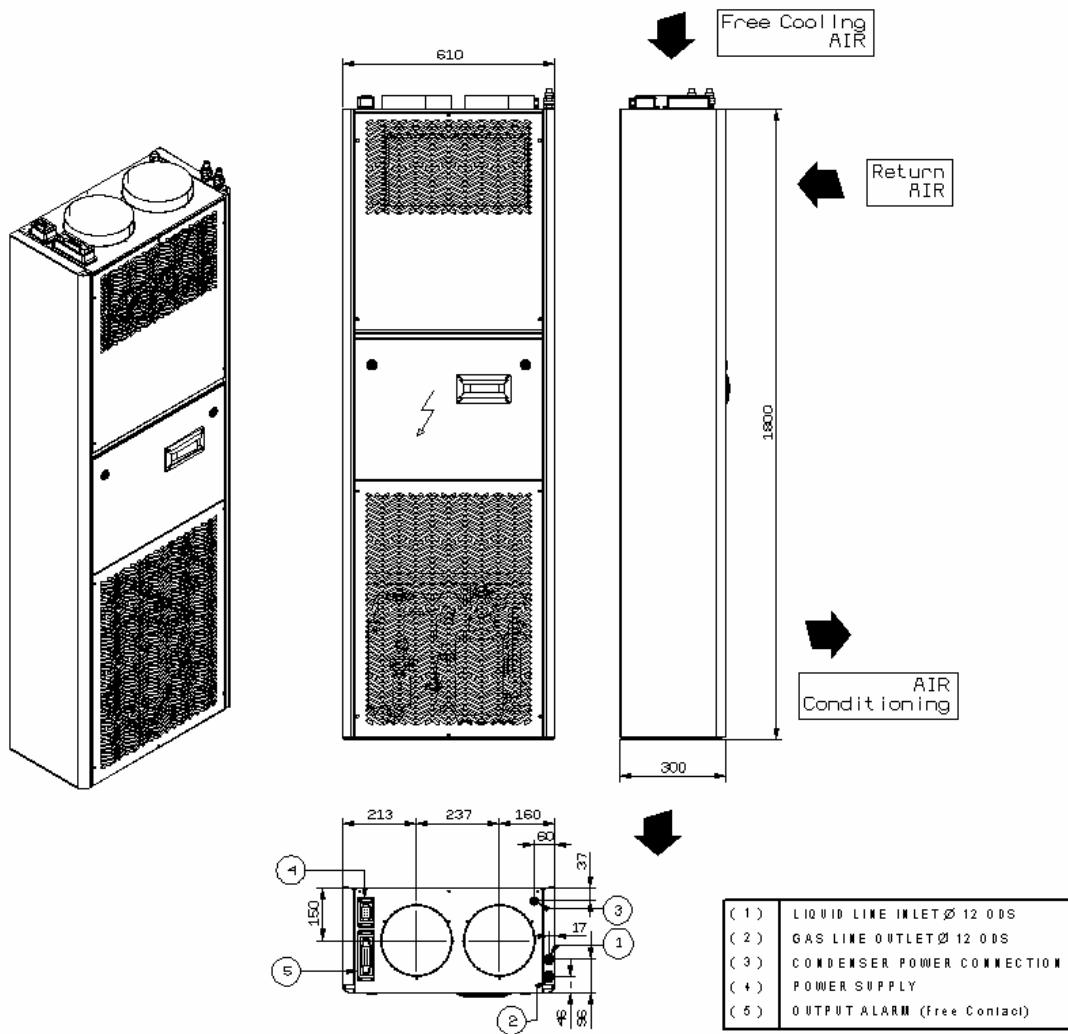



High Technology in Refrigeration Devices



High Technology in Refrigeration Devices

HiRef S.p.A Via Umbria, 5/c - 35043 Monselice (PD) – Italy
Tel. +39 0429 784683 - Fax +39 0429 701447
e-mail: info@hiref.it - Web: <http://www.hiref.it>